

Test bench for hydraulic tools Type PH



Suitable for:

- adjusting and testing tools before screwing
- inspection conform with DIN EN ISO 9000ff
- tabulate the relation of working pressure to torque
- portable test bench

Delivery without specimen
and torque support block

Description:

With the test bench type PH it's easy to adjust and test hydraulic tools or tabulate the relation of working pressure to torque.

With the supply and display unit GMV2 the measurements can be displayed and documented.

Tools with driving squares conform with DIN 3121 can plugged in directly.

For connect the tools are various adpters available. Tools for hexagon bolts can be connected with various hexagonal adapters (look for specification sheet „PH-hexagonal adapters“).

Mechanical dimensions:

Dimensions	L	B	H
3; 6; 10 kNm	464	210	259
16; 20 kNm	571	250	374

measuring range	square sockets	
3.000 Nm	1"	-
6.000 Nm	1"	1 1/2"
10.000 Nm	-	1 1/2"
16.000 Nm	2 1/2"	1 1/2"
20.000 Nm	2 1/2"	-

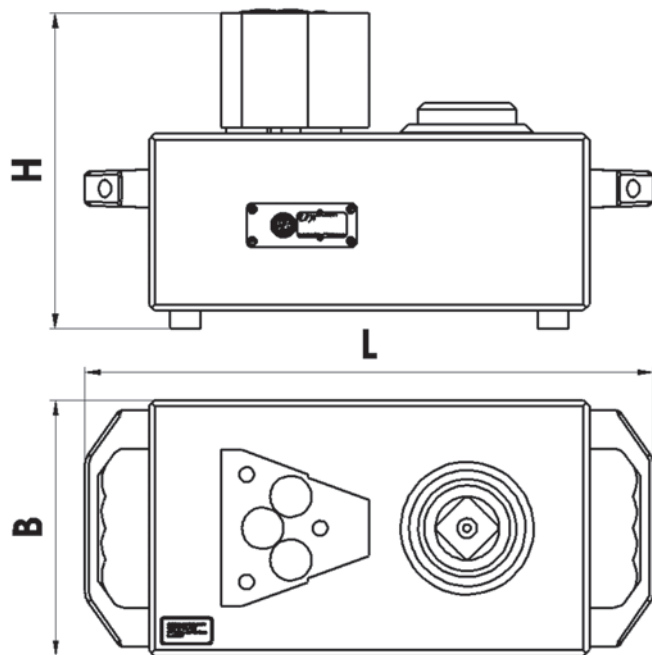

Technical Data:

Type:	(a)ctive	(p)assive
Measuring range:	3; 6; 10; 16; 20 kNm	
Supply Voltage:	12V DC±10%	12 V max.
Current Consumption:	approx. 20mA	35mA max.
Voltage Output:	0- ±5V	2mV/V
Nonlinearity:	<0,5 %	<0,5 %
Hysteresis:	<0,1 %	<0,1 %
Internal Resistance:	---	350 Ω nominal
Compensated Temp. Range:	5-45°C	5-45°C
Operating Temperature:	0-60°C	0-60°C
Temperature fault		
Zero Point:	0,02 % / K	0,02 % / K
Sensitivity:	0,01 % / K	0,01 % / K
Mechanical Overload:	50%	50%
Weight 3; 6; 10 KNm:	approx. 40 Kg	approx. 40 Kg
Weight 16; 20 KNm:	approx. 90 Kg	approx. 90 Kg
Connection:	12 pin Connector	6 pin Connector
Protection:	IP 40 conform to DIN 40050	IP 40 conform to DIN 40050

Available Adapters: look at specification sheet „PH- hexagonal adapters“

Please ask for adapters not listed above.

1. Ordering Example: PH-3p-1“

Torque transducer - measuring range 3 kNm passive – 1“ square socket conform with DIN 3121

2. Ordering Example: PH-20a-2 1/2“

Torque transducer - measuring range 20 kNm active – 2 1/2“ square socket conform with DIN 3121

Available Accessories: Adapter, Measuring Cable, Supply and Display Unit Type GMV2